

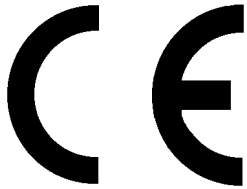

O W N E R G U I D E



**MODEL BR419**  
**(G.C. 32-032-08)**  
**Inset Live Fuel Effect**  
**Gas Fire**  
**with**  
*Ultimate Fireslide*  
*Colourway*  
*Superflame*  
*Or*  
*Homestyle*  
*Front*



*This Owner Guide is intended to help you care for your Valor gas fire.  
Please read carefully before using your gas fire and keep for future reference.  
This Owner Guide gives sufficient details to enable your gas fire to be operated and  
maintained.*

**IMPORTANT.**  
**Please keep your Owner Guide in a safe place together with the  
Installer Guide.**

As supplied, this appliance is for use with natural gas (G20)  
When converted using Valor conversion kit no. 591149 this appliance  
is for use with propane gas (G31)  
This appliance is for use in the United Kingdom (GB) and the Republic  
of Ireland (IE) only.

## C U S T O M E R C A R E

### *Thank you for choosing Valor.*

All Valor gas fires are designed to meet the most stringent quality, performance and safety requirements to provide our customers with many years' trouble-free service.

Your owner guide aims to improve your understanding and appreciation of your Valor gas fire by providing simple and informative instructions to ensure that you benefit from the excellent performance and features it has to offer.

If you require further assistance or any advice about gas in general, the **Valor AdviceLine** will be pleased to help.

Please telephone **0345-626341** (local call rates apply in the United Kingdom).

**FOR OTHER USEFUL TELEPHONE NUMBERS SEE INSIDE BACK COVER.**

## C O N T E N T S

	Page
Safety -----	3
Major Dimensions -----	4
Gas Consumption -----	4
Operating the Fire -----	5
Cleaning -----	6
Fuel Bed Refitting -----	7
Maintenance -----	8
Useful Telephone Numbers -----	Inside back cover

## SAFETY

### IF YOU SMELL GAS

**DON'T SMOKE**

**EXTINGUISH ALL NAKED FLAMES**

**DON'T TURN ELECTRICAL SWITCHES ON OR OFF**

**TURN OFF THE GAS SUPPLY AT THE METER**

**OPEN DOORS AND WINDOWS TO GET RID OF THE GAS**

**IMMEDIATELY CALL THE GAS EMERGENCY SERVICE - SEE YOUR LOCAL TELEPHONE DIRECTORY**

1. As with any gas appliance, this fire must be installed by a competent person. In the United Kingdom, installation must be in accordance with the latest edition of the Gas Safety (installation & use) Regulations.  
In the Republic of Ireland, installation must be in accordance with all national and local regulations in force.
2. If the fire is intended to be installed to a chimney which was previously used for solid fuel, please note that the chimney must be swept prior to installation.
3. On no account must the fire stand on carpets or other combustible materials. The fire must stand behind a non-combustible hearth surface. The hearth material must be at least 12mm thick. Its top surface should be 50mm above floor level to discourage placing carpets. Rugs or other combustible materials over the hearth. The minimum size of the hearth is shown in figure 1.
4. If the fire is intended to be installed against a wall with combustible cladding, the cladding must be removed from the area covered by the outer surround (see figure 1).
5. The minimum height from the top surface of the hearth to the underside of any shelf made from wood or other combustible material and which is not more than 150mm deep is 750mm. For shelves deeper than 150mm add 12.5mm to the above clearance for every 25mm of additional shelf depth.
6. Never put any paper or other material on the fire. Never add any extra coals above the number stated in these instructions. This could cause a safety hazard.
7. It should be appreciated that although this appliance conforms to all the applicable standards, it is a decorative fuel effect heating appliance and certain parts of its surface will become hot. A suitable guard which complies with BS 6539 or 6778 should be used for the protection of young children, the elderly and the infirm. Such a guard is also recommended for the protection of pet animals.
8. Always switch the fire off and allow to cool before handling. Note that this appliance retains heat for some time after it has been switched off.
9. Never hang clothing, towels or any other fabrics over the fire.
10. This appliance is fitted with a device which will automatically shut off the supply of gas to the fire if, for any reason, the flames go out. If this device does operate or if the fire is turned off accidentally or intentionally, always wait three minutes before attempting to relight.
11. Soft wall coverings (e.g. embossed vinyl etc.), are easily affected by heat. They may, therefore, scorch or become discoloured when close to a heating appliance. Please bear this in mind when having a heating appliance installed and when redecorating.

#### Please note

When operating your fire for the first time, some vapours may be given off which may cause a slight odour and could possibly set off any smoke alarms in the immediate vicinity. These vapours are quite normal with new appliances. They are totally harmless and will disappear after a few hours use.

This fire is supplied with ceramic "coals" to simulate a real coal fire. These items are safe to handle and are designed for easy refitting if removed.

After some use, the ceramic walls and coals may change colour. This is quite normal.

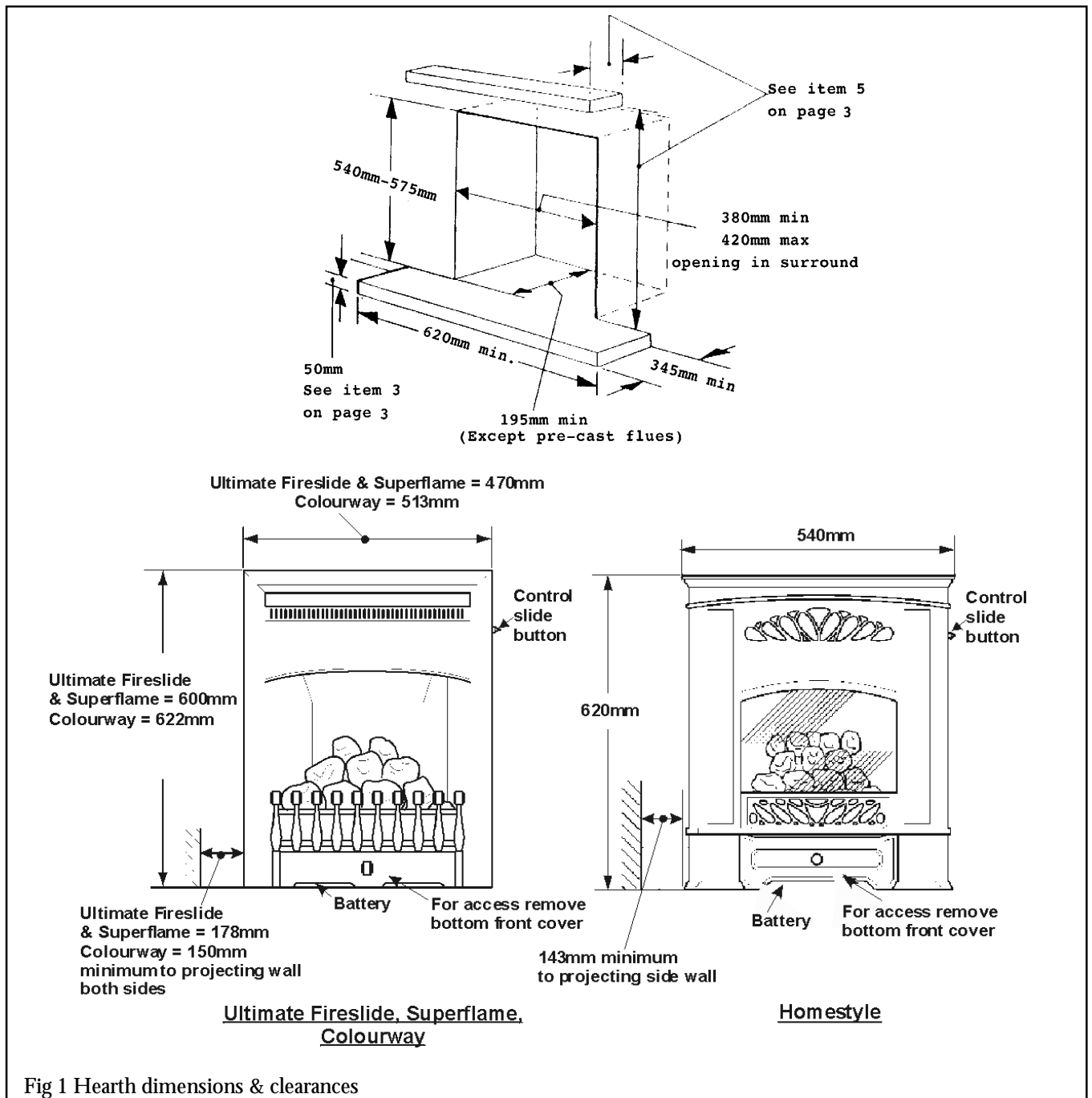

## GAS CONSUMPTION

Natural gas appliances have a maximum gas input at the high setting of 6.0kW (Gross) and a minimum gas input at the low setting of 2.7 kW (Gross).

Propane gas appliances have a maximum gas input at the high setting of 6.1kW (Gross) and a minimum gas input at the low setting of 4.3 kW (Gross).

To calculate the running cost of this fire, multiply the gas consumption (gas input) by the cost of gas which you will find on your gas bill.

$$\text{GAS CONSUMPTION (HEAT INPUT)} \times \text{COST OF GAS} = \text{RUNNING COST}$$

Natural gas appliances have a heat output of 3.5kW at the high setting and 1.3kW at the low setting.  
Propane gas appliances have a heat output of 3.6kW at the high setting and 2.1kW at the low setting.

## OPERATING THE FIRE

### The flame sensing & flue blockage safety system.

For your safety, this appliance is fitted with a flue blockage safety device which will shut down the appliance in the event of abnormal flue conditions. **This device is NOT a substitute for an independently mounted Carbon Monoxide detector.**

The device will also automatically shut off the gas supply to the fire if the pilot flame goes out due to lack of oxygen or for any other reason.

**If this device starts to repeatedly shut off the gas, get expert advice.**

This device incorporates a probe which senses that the heat from the pilot flame is correct. If this probe is cool, the device will prevent any gas flow unless the sliding control button is held at the ignition position.

If, for any reason, the flames go out when the fire is hot or if the fire is turned off when hot, always **wait at least three minutes before attempting to relight.**

### To light the fire

The **FireSlide** control is shown in figure 2.

1. Slide the control button to the bottom (ignition) position marked **I**.

In this position, the electronic ignition system should cause a series of sparks which should light the pilot. Within four seconds of the pilot igniting, the main burner should light at its minimum setting. If no sparks are produced to light the pilot, the battery may need replacing. Details of battery replacement are given further on in this manual.

Until you can obtain a replacement battery the fire can be lit with a taper as described later in the instructions.

2. Keep the button at the ignition position for a further ten seconds. This will prevent the flame sensing device from shutting off the gas while its probe warms up as explained above.

3. If low heat is required, release the button. The button will automatically spring up to the low heat position shown in figure 2 (See note i below).

4. For a higher heat level slide the button upwards. The burner flames and heat output will gradually increase until the button reaches the high heat position shown in figure 2. When the button reaches the high heat position you will feel a check to its movement. **Do not slide the button above the high heat position unless you want to turn the fire off** (See note i below).

#### **Note**

i. If the flames go out while setting the control, repeat the full lighting procedure. If the flames repeatedly go out have the fire serviced.

ii. Please note. When first turned on the flames will appear predominantly blue. The coals will take time to warm up. Although some glow will be seen after approximately ten minutes, the full visual effect will only be apparent after a somewhat longer time.

iii. The appliance will operate to its maximum potential if the flue is primed during the first 20 – 30 minutes of operation. To do this, simply turn the control knob to its highest setting. This will also burn off any carbon deposits that may have formed during previous operations.

iv. If operating the appliance for long periods it is beneficial to change between settings. This will also help to remove any carbon deposits that may form during operation.

### To turn the fire off

Slide the button up past the high heat position to the "O" position until the flames extinguish. Both the main burner and the pilot should go out. While cooling, the coals may make some crackling noises. This is quite normal.

### Lighting with a taper (see figure 3)

In the unlikely event of failure of the ignition spark, the pilot can be lit by a taper or long spill. Insert the taper or spill alongside of the left side wall of the fire box and operating the slide control as described above.

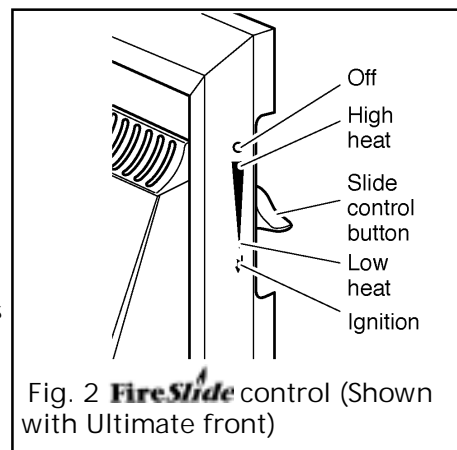

Fig. 2 **FireSlide** control (Shown with Ultimate front)

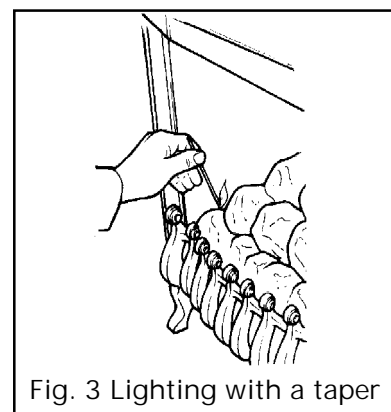

Fig. 3 Lighting with a taper

## CLEANING

Turn the fire off and allow it to cool before attempting any cleaning. Note that the fire will retain heat for some time after it has been turned off.

**If large pieces of debris are found anywhere in the fireplace, have the chimney inspected before further use.**

### **Metal parts**

Clean the metal parts with a slightly damp cloth and then dry. **Do not use abrasive cleaners, they could scratch the surface.**

### **Coals and burner compartment walls**

This product uses ceramic fuel effect pieces. It makes sense to take care when handling these articles so that the release of dust is kept to a minimum.

#### Coals

Light coatings of soot will usually be burnt off during the normal operation of the fire. If, however, deposits of soot or particles of sand, mortar, etc. from the chimney accumulate to 3mm ( $\frac{1}{8}$  in) or more, these should be removed from the coals by dismantling them and cleaning with a soft brush. We suggest that you remove the coals in the reverse order to that shown in the fuel bed refitting instructions on the next page. *Cleaning with a vacuum cleaner is not recommended because it may damage the coals.*

#### Ceramic fire box walls

Clean with a dry soft brush. *Cleaning with a vacuum cleaner is not recommended because it may damage the walls.*

### **Ceramic burner**

Remove any deposits of soot or other foreign matter from the solid areas of the burner with a dry soft brush. Be careful not to brush any particles into the open slots. Remove any particles from the slots with a vacuum cleaner fitted with a soft brush attachment. **Do not poke wire, etc. into the slots in the burner.**

## FUEL BED REFITTING

If the fuel bed components are dislodged or removed, they must be refitted as follows:

**Only the fuel bed parts supplied with this appliance or authorised Valor replacements must be used. Never add extra coals above the number stated in these instructions.**

1. With its feather edge at the top, place the ceramic rear wall into the channel at the back of the fire box. Push the wall flat against the rear of the fire box. (See figure 4).

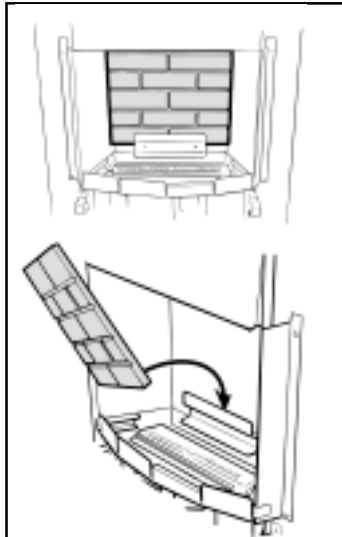

Fig. 4 Ceramic rear wall installation

2. Place the two halves of the front base coal in the burner compartment so that they rest on the ledges at the sides and front. Pull the coals forward so that they are **immediately behind the front rim of the burner compartment** (See fig. 5).

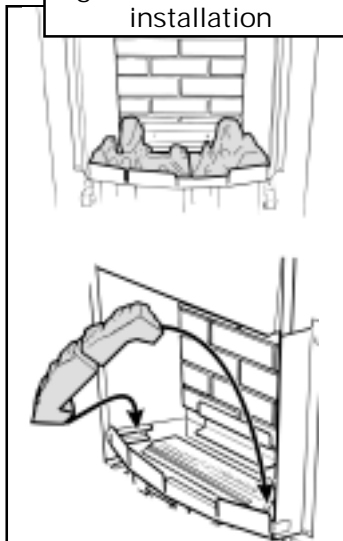

Fig. 5 Front coal installation

3. Place the rear base coal in the burner compartment behind the front coal. Its rear face should touch the rear ceramic wall (See figure 6).

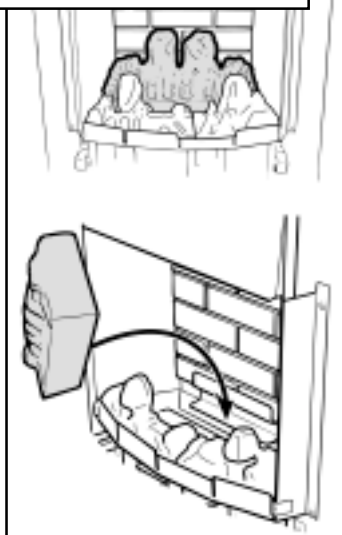

Fig. 6 Rear base coal installation

4. The ceramic side walls are marked at the rear bottom corners "L" (Left side) & "R" (Right side). Place the side walls against the sides of the fire box and in the recesses at the sides of the base coals. The markings "L" & "R" should be at the back bottom corners and facing to the centre of the back of the firebox (See figure 7).

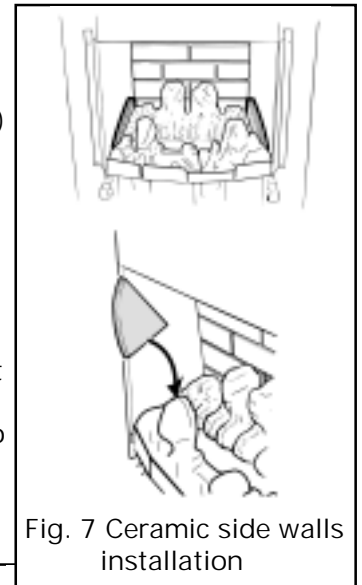

Fig. 7 Ceramic side walls installation

5. Install the 5 loose coals as follows. The smooth surfaces of the coals should be at the bottom and back.

5.1 Select the two largest coals. Place them in the central two valleys of the front coal (See figure 8).



Fig. 8 Front row inner coals

5.2 Place the three remaining coals behind and approximately midway between each of the coals in the front row (See figure 9).

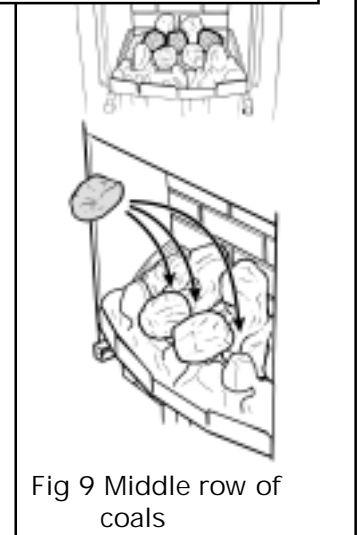

Fig 9 Middle row of coals

## MAINTENANCE

### Battery replacement

(See fig 10).

This appliance requires 9V PP3 Ever Ready Silver Seal (or equivalent) battery.

To replace the battery remove the bottom front cover casting.

Fit the new battery firmly to the connections on the generator, the positive battery terminal (+) being to the right as you insert.

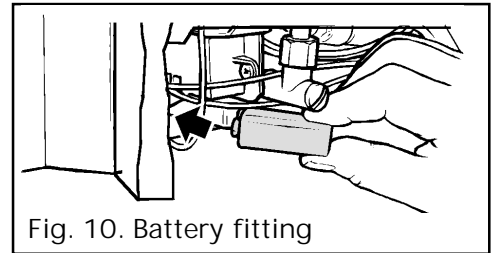

### Fitting Tile sets – Homestyle Only

A wide range of alternative tile designs are available from your supplier.

To change the tiles:-

1. The top casting will have to be removed to insert the tile set. Some appliances have the top casting secured to the sides by screws. Other appliances have the top secured by spring clips. If the top is screwed to the sides, unscrew the two screws at the top of the side castings until they are loose enough to allow the top to be lifted off. There is no screw thread in the top casting, only in the side castings (See figure 11). If no screws are visible, the top can be removed by pulling it firmly upwards to release the spring clips (See figure 11).
2. a) Remove the complete tile cassette by sliding the cassette channel up and out of the front casting. See figure 11.  
b) Alternatively, remove the tiles individually by sliding them up out of the cassette channel. This second method will have to be employed if a shelf above the fire is too low to enable the channel to be slid clear.
3. Fit the new tile cassettes by sliding them in the grooves at the back of the front casting and in front of the spring clips. Alternatively, if any shelf above the fire is too low to fit the full cassette, remove the new tiles from the cassette and individually slide them into the old cassette channel.
4. Replace the top casting and, if applicable, secure by tightening the two screws.

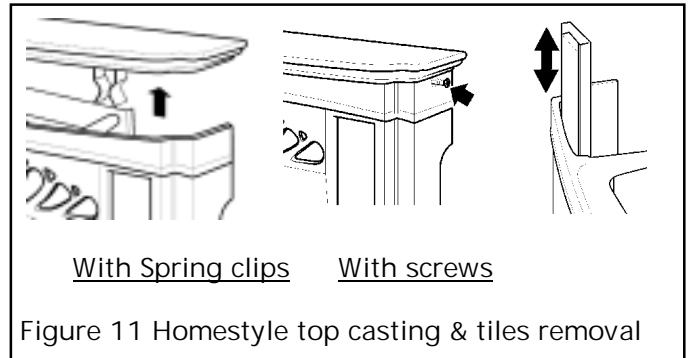

### Regular maintenance

In order to achieve and maintain high levels of personal safety and performance efficiency, it is essential that the opening at the back of the fire and the flue are kept clear of any form of obstruction. It is possible that deposits of mortar or soot could fall and accumulate causing the flue to be blocked or restricted and so preventing proper clearance of dangerous exhaust fumes.

In the United Kingdom it is the law that a landlord must have any gas appliance, flue and pipework which is situated in a tenant's premises checked for safety at least every twelve months by a competent person (In the U.K, a CORGI registered installer).

We recommend that all gas appliances and their flues, wherever situated, are checked annually.

### Servicing

- ▶ In the United Kingdom servicing can be carried out either by a Valor Service engineer or a CORGI registered installer.  
If you require your fire to be serviced by a Valor service engineer please contact **Valor Service** on **0121 386 6203** and quote the following details;
  - a) model name and number.
  - b) appliance serial no. (To be found below the burner and behind the bottom front cover)
- ▶ If you wish to replace any of the owner replaceable parts listed below, please contact **Valor Sales** on **0121 386 6260** for your nearest stockist of these parts. When ordering please quote the part number shown below.

**In the Republic of Ireland call 353 183 75114 for all enquiries.**

<u>Description</u>	<u>Part No</u>
Rear wall	545999
Front base coal halves	569449
Rear base coal	569459
Pack of 5 top coals	569469
Right side wall	546039
Left side wall	546049

When fitting replacement parts, follow the instructions contained in this guide. It is important that only Valor approved parts are used for maximum safety.



## USEFUL TELEPHONE NUMBERS

**To help us quickly help you, please try to have the following information available before you contact us:**

- a) Your Post Code.
- b) Type of fire.
- c) Model/Name.
- d) Serial Number.
- e) The fault, problem or request.

General advice about gas and your gas fire:

VALOR ADVICELINE 0345 626341.

To report faults or arrange for your fire to be serviced:

VALOR SERVICE 0121 386 6203.

To order spares or for sales information:

VALOR SALES 0121 386 6260.

CALLERS IN THE REPUBLIC OF IRELAND

Call 353 183 75114

### **Safety First.**

Valor fires are CE Approved and designed to meet the appropriate British Standards and Safety Marks.



### **Quality and Excellence.**

#### **At the heart of every Valor fire.**

All Valor fires are manufactured to the highest standards of quality and excellence and are manufactured under a BS EN ISO 9001 quality system accepted by the British Standards Institute.



### **The Highest Standards**

Valor is a member of the Society of British Gas Industries which works to ensure high standards of safety, quality and performance.



### **Careful Installation**

Valor is a Corgi registered company. All our gas fires must be installed by a competent Corgi Registered Installer in accordance with our Installer Guide and should not be fitted directly on to a carpet or floor of combustible material.



Valor Heating, Erdington, Birmingham B24 9QP

Because our policy is one of constant development and improvement, details may vary slightly from those given in this publication.